

- A SEA WATER DRAIN POINT, 2x
- B SEA WATER INLET, CONNECTION FOR 63 mm (2 1/2") I.D. HOSE
- C1 WET EXHAUST BEND WITH RISER, OPTION 1
- C2 EXHAUST FLANGE, OPTION 2, MAX LOAD 9KG
- D FLEXIBLE SUSPENSION, STANDARD EQUIPMENT
- E1 OIL DIPSTICK AND FILLING ENGINE STARBOARD SIDE ALTERNATIVE
- E2 OIL DIPSTICK AND FILLING ENGINE PORT SIDE ALTERNATIVE
- F OUTLET FOR OIL BILGE PUMP (M18x1.5)
- G FRESH WATER FILLING (EXPANSION TANK)
- H FRESH WATER DRAIN POINT (3x)
- I OIL FILTER, 2x
- J BYPASS OIL FILTER
- K FUEL FILTER/ WATER SEPARATOR
- L PRIMER PUMP
- M FUEL DEARATION
- N DIAGNOSIS CONNECTION (6-POLE)
- D CONNECTION SENDERS (6-POLE)
- P DATA LINK CONNECTION (16-POLE)
- Q CONNECTION EVC (REVERSE GEAR/2-POLE)
- R1 CONNECTION BATTERY POS.
- R2 CONNECTION BATTERY NEG.
- S AIR FILTER
- T PRESSURE DROP INDICATOR, AIR FILTER
- U LIFTING EYE, 3x (1030 MIN. FRONT EYE REMOVABLE)
- V HOSE CONNECTION HOT WATER OUTLET R1/2" I.D. HOSE, OPTIONAL EQUIPMENT
- W HOSE CONNECTION HOT WATER INLET R1/2" I.D. HOSE, OPTIONAL EQUIPMENT
- X FUEL CONNECTION INLET
- Y FUEL CONNECTION OUTLET
- Z PRESSURE LUBRICATION OF PROP. SHAFT (1/4-18NPS)
- AA SEA WATER OUTLET FOR 2 1/8" I.D. HOSE (I.D. 54mm)
- AB EXTERNAL STOP CONNECTION
- AC CAN2 CONNECTION
- AD AUTOMATIC FUSE, 10A (ENGINE)
- AE STOP BUTTON
- AF AUTOMATIC FUSE, 10A (EVC)
- AG OIL DIPSTICK AND FILLING TRANSMISSION
- AH OIL DRAIN TRANSMISSION
- AI EMERGENCY SHIFTING

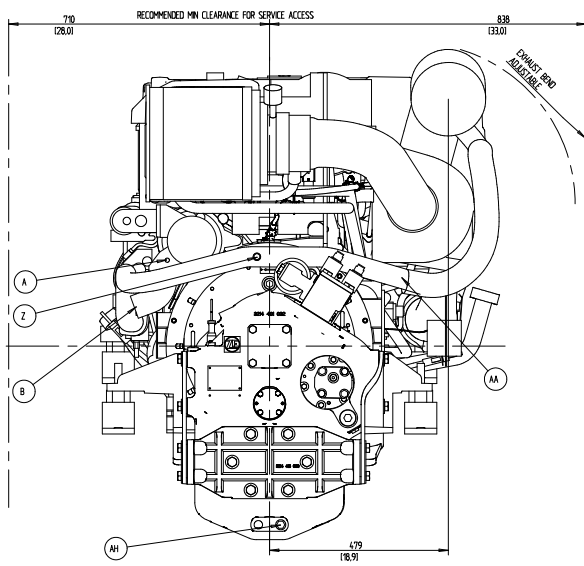
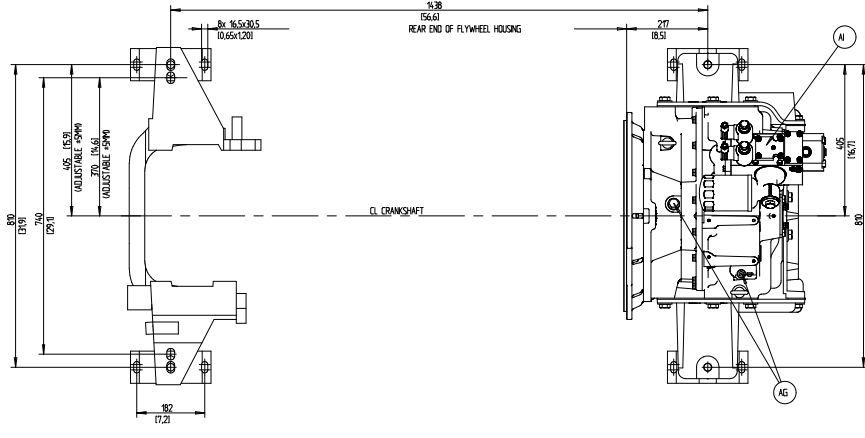

SCALE 1:5
 WET WEIGHT 1768KG (WITH OIL AND WATER)
 DRY WEIGHT 1668KG (WITH OIL AND WATER)
 DIMENSIONS IN MILLIMETRE AND INCHES

VOLVO PENTA 21353182	ENGINE DIMENSIONS 0108-B MP REVERSE GEAR 2F 305 IV
	DISPOSITION DRAWING 21353182